



Vacuum Filler



Leader Evaporator Co., Inc.

49 Jonergin Drive

Swanton, Vermont 05488

(802) 868-5444

www.leaderevaporator.com

VACUUM FILLER OPERATING INSTRUCTIONS

Contents

DESCRIPTION.....	2
EQUIPMENT DESCRIPTION.....	2
OPTIONAL SPARE PARTS AND OPERATIONAL SUPPLIES.....	3
SETUP OF THE VACUUM FILLER.....	3
OPERATING THE VACUUM FILLER.....	6
MAINTENANCE	7
AFTER EACH USE:.....	7
PERIODIC	7
END OF SEASON	7
FEEDBACK.....	7

DESCRIPTION

The LEADER EVAPORATOR Vacuum Filler is designed to aid the maple syrup packer in filling glass containers especially the smaller containers which do not lend themselves to easy filling with regular faucet type apparatus. The vacuum filler is designed to be used with glass containers with top external dimension not exceeding 1.25”.

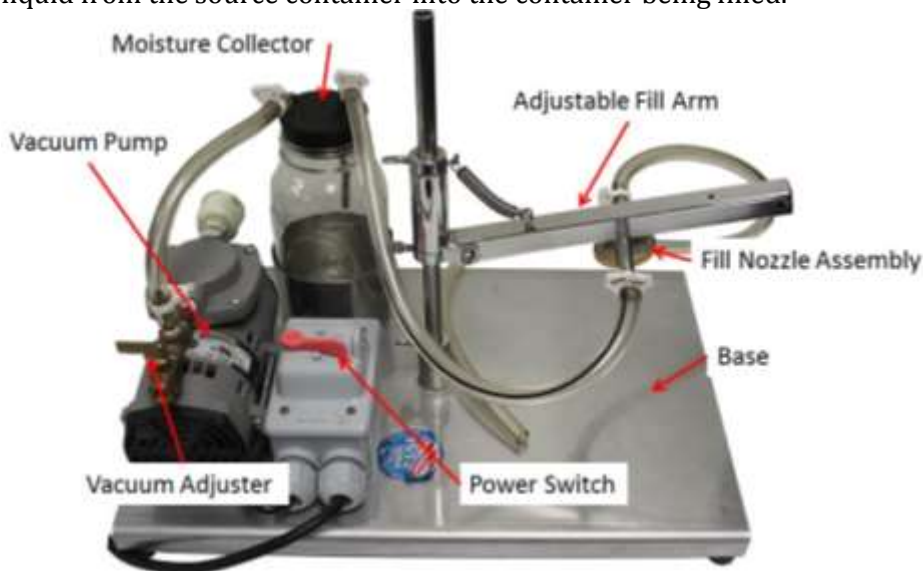

EQUIPMENT DESCRIPTION

The unit operates by creating a vacuum in the container being filled. The vacuum created then draws the liquid from the source container into the container being filled.



VACUUM FILLER OPERATING INSTRUCTIONS

OPTIONAL SPARE PARTS AND OPERATIONAL SUPPLIES

ITEM	LEADER ORDER #	DESCRIPTION / PHOTO	ITEM	LEADER ORDER #	DESCRIPTION / PHOTO
PVC Tubing for Vacuum Filler	61154		Regulator Packing (Specify use is for vacuum filler)	59066	

SETUP OF THE VACUUM FILLER

1. Select a location for the unit
 - a. Use a stable level surface
 - b. Enough workroom to allow for the heated syrup container, the containers to be filled and containers that have been filled
2. Determine whether front or back of the unit is best for the source or for ability to fill the containers. This will vary by the location.
3. Follow these directions if it is necessary to change the fill or source sides.



- a. Unhook the spring from the upright then remove the screw from the fill arm holding the spring between the fill arm and the upright shaft. The nut below the spring on the screw should remain in approximately the same position.
- b. Remove the nut from the bolt that is holding the fill arm in the bracket attached to the upright shaft. Then remove the bolt from the bracket and fill arm.

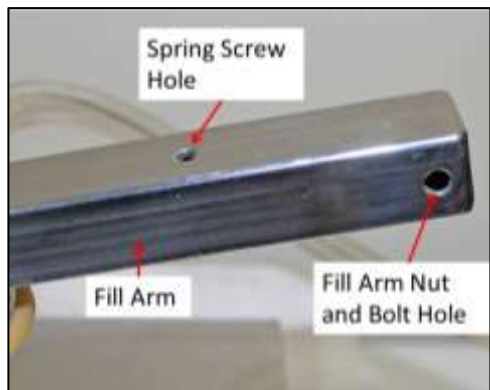

- c. Reverse the fill arm. You will note on the end of the fill arm opposite the one removed from the upright is another set of mounting holes.
- d. The fill nozzle assembly is to remain facing down.

VACUUM FILLER OPERATING INSTRUCTIONS



- e. Turn the tubing elbow entering the moisture collector to line up with the new direction of the tubing from the fill arm.
- f. Slide the end of the fill arm into the bracket on the upright and push the bolt through the holes in the bracket and the fill arm. Thread on the nut and tighten just enough to secure.
- g. Thread the screw with the spring into hole on the top of the fill arm and tighten. Hook the spring onto the hook on the upright.

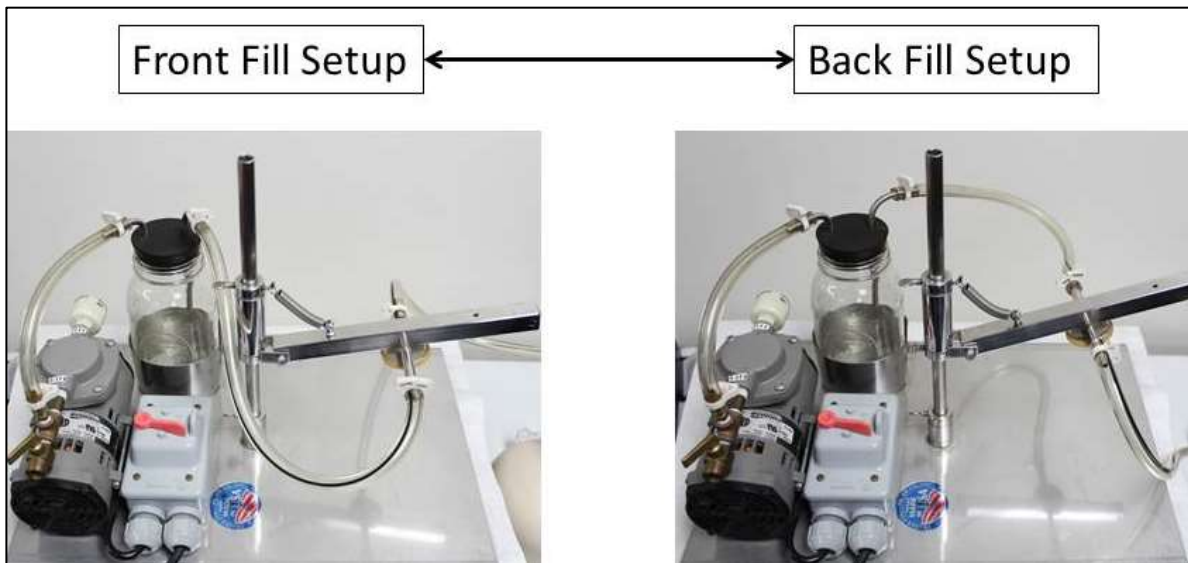

4. Select a glass container to be filled and place it on the base of the unit lining up with the fill nozzle assembly
5. The fill arm will pivot down when pressed. Press the fill arm down while at the same time lining up the container so the nozzle will be in the center of the container top

VACUUM FILLER OPERATING INSTRUCTIONS

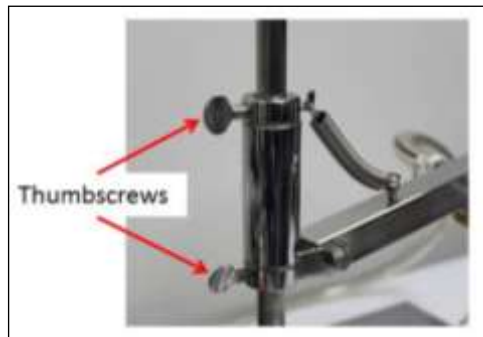

6. Adjust the fill arm so the bottom of the seal on the fill nozzle assembly is parallel to the top of the bottle (will seal all around the top of the bottle). To adjust the fill arm:
 - a. Loosen the two thumbscrews in the fill arm near the upright shaft.
 - b. Slide the fill arm up or down on the shaft as needed to position the nozzle.
 - c. Tighten the thumbscrews to hold the fill arm in place.
7. Place the moisture collector jar into the holder then ensure the top is pressed in it securely.
8. Plug the unit into a standard wall outlet.
 - a. 110 / 115 Volts
 - b. 2.0 / 1.7 Amps
9. When using the unit for the first time or after a period of storage, do the following:
 - a. Fill a container $\frac{1}{2}$ full with clean non chlorinated hot water.
 - b. Place the glass container under the fill nozzle.
 - c. Turn on the unit.
 - d. Pull the fill arm assembly down onto the glass container until the water starts to fill the container.
 - e. Continue letting the water flow. It will over fill the container which will send water into the moisture collector. Lift the fill arm assembly off the container when the moisture collector is $\frac{1}{2}$ full.
 - f. Turn off the unit.
 - g. Remove the top from the moisture collector, empty and dry out the collector jar. Empty the glass container.

VACUUM FILLER OPERATING INSTRUCTIONS

OPERATING THE VACUUM FILLER

The following picture represents how the unit should be setup. Containers will vary dependent on individual usage. The source container shown is for illustration purposes.

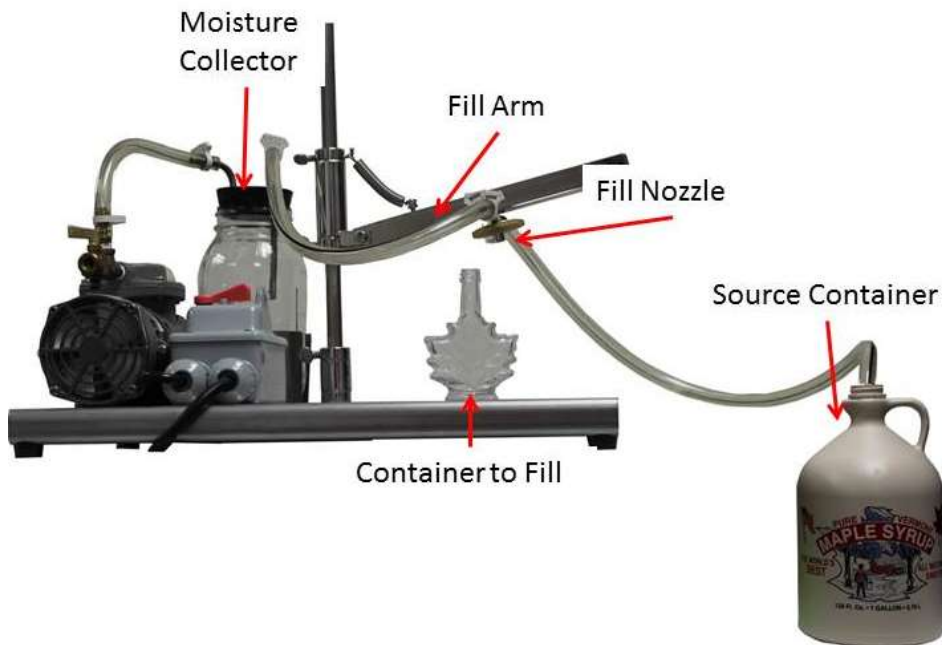

NOTES:

- When using the unit, remember the materials being handled are hot.
- When adjusted correctly the moisture collector should collect very little syrup. If syrup does collect, stop using the unit when the syrup fills the moisture collector ½ way. Remove, empty and clean the jar then reinstall it.
- The adjustment for glass container size should only be required when changing from one size/type to another.

1. Heat the filtered syrup to be bottled. The syrup must be kept at a 185°F or higher when packaging in glass. When packaging in glass all syrup should be filtered after being heated.
2. Position the container with the heated syrup close enough to the vacuum filler so the source hose from the vacuum filler can reach the bottom of the container. The source container needs to be lower than the nozzle to allow the syrup to drain back.



3. Set the vacuum adjuster approximately halfway open.
4. Position the bottle to be filled under the fill nozzle.
5. Turn on the unit.

VACUUM FILLER OPERATING INSTRUCTIONS

6. Lower the fill nozzle onto the bottle until the bottle begins to fill with syrup. Watching the bottle, adjust the vacuum adjuster until the flow results in no foam.
NOTE: If there is foam in the source container it will be carried to the moisture collector during the start of the process.
7. When the bottle has been filled lift the fill arm assembly off the end of the bottle.
NOTE: If the unit does not draw syrup into the bottle, check the bottle for a crack or pinhole and ensure the vacuum adjuster is not open too far.
8. Position the next bottle under the fill nozzle and lower the fill arm so the fill nozzle seals and starts the flow of syrup. Lift the fill arm when the bottle is filled. Place the cap on the bottle and seal.
9. Repeat Step 8. Until all containers are filled. Shut off the unit.

MAINTENANCE

Use only non-chlorinated water when cleaning the unit.

AFTER EACH USE:

Cleaning The Unit

1. Remove the source hose from the syrup container.
2. Place any glass container under the fill nozzle and adjust the fill arm to accommodate the container.
3. Obtain a container of hot non chlorinated water and place the source hose into it.
4. Start the unit.
5. Draw the hot water through all the system piping including up to the moisture collector. Do NOT fill the moisture collector over half full. Shut off the unit.
6. Remove the top from the moisture collector jar. Empty, clean and wipe out the moisture collector jar.
7. Wipe down all parts of the unit as required.

PERIODIC

1. Inspect the tubing for wear or damage. Replace as necessary.
2. Inspect the regulator packing used in the fill nozzle assembly. If it is worn and the seal cannot be made well to the bottles, replace the packing.

END OF SEASON

1. Clean the unit as described in the Cleaning the Unit section.
2. Inspect all the hoses for wear or damage. Replace as necessary.
3. Inspect the regulator packing used in the fill nozzle assembly. If it is worn and the seal cannot be made well with the bottle, replace the packing.
4. Cover the unit and place it in an area protected from insects and other pests.

FEEDBACK

Please use the following e-mail address (feedback@leaderevaporator.com) to suggest improvements or enter comments on this document. Reference the document title in your note. You may also contact LEADER Customer Service.